

SPG

supplementary planning guidance

Provision for digital ducting within new development



WEST LOTHIAN COUNCIL delivers

westlothian.gov.uk



**West Lothian
Council**

Supplementary planning guidance

PROVISION FOR DIGITAL DUCTING WITHIN NEW DEVELOPMENT

Introduction

1.1 This supplementary planning guidance (SPG) is designed as a high level guidance note for housing and other developers who intend or who wish to consider the laying of ducting on development sites, and within dwellings and business premises, for the delivery of data services. Data services today are becoming important to the house buyer and are increasingly being taken into consideration by prospective purchasers when they are looking for a new home. The buyer will want flexible data services that will impact positively on their quality of life. Data services are also key to many businesses operating efficiently and effectively. The guidance will highlight to potential developers at an early stage the opportunity they have to consider providing digital ducting infrastructure to carry the cabling for digital services to serve their proposed developments.

1.2 West Lothian is well placed geographically in terms of its location within the central belt between Edinburgh and Glasgow to benefit from the economic advantages of proximity to key transport links such as the M8, M9 and Edinburgh to Glasgow railway lines as well as proximity to Edinburgh Airport. However, there is also a need to provide digital infrastructure that ensures the area is well connected, particularly in terms of internet broadband provision.

1.3 Data services come in many guises offering not just broadband services such as email and internet access, but entertainment from all over the world. Digital Television, video on-demand and international radio are just a few of the services that are possible and are currently

available. The range of such services will grow in future. The Digital Television Switchover taking place between 2008 and 2012, is one initiative which will result in significant change. As services grow the demand increases, services will

evolve to give the consumer greater choice and flexibility. Personal communication is seen as the leader, no longer limited by distance and cost, with new services offering low cost or free communication between people from any country.

1.4 Further, as more people work from home, there is an increasing demand for data services to enable them to conduct business as if they were in an office. People are now taking this into account when buying a home, looking for space for an 'office' and the availability of broadband connectivity. Furthermore, Intelligent Homes can exploit data service connectivity and deliver new services to residents, manage heating and energy usage automatically to help reduce carbon emissions and wasted energy.

1.5 This SPG is not intended to promote a particular technology and it needs to be recognised that when new technologies are introduced, parts of the document may become out of date.

get set for digital 

1.6 Although this SPG refers to ducting, cabled and fibre technologies data service delivery is by no means limited to wiring and wireless technologies offer an alternative. It is expected that the demand for such services will increase and it is felt that doing nothing is becoming less of an option.

1.7 Digital ducting is the physical infrastructure underground that can carry the cables associated with digital technologies and can sit alongside traditional infrastructures such as telephone and electricity.

1.8 Technology is allowing for greater freedom and choice than ever before, giving people more free time. People today use technology in a variety of ways that benefits them and their local community. Many local groups are formed in the digital world and distant communications are no longer associated with high costs and long delays.

1.9 Data services to homes are now more popular than ever before offering greater choice and competitive prices to the consumer. These services come in many guises offering television, radio, internet access, security, etc. As demand for such services increases so will the need for new dwellings to include these services as the norm.

1.10 Currently data services are delivered in a variety of ways including using:

- the infrastructure that delivers standard telephony services
- a cable television network
- a dedicated multi-services broadband network
- mobile telephony, wireless and satellite to offer flexibility and deliver services to areas that cannot access other services.

1.11 As the take up of broadband and associated data services has increased it has become apparent that people will demand a data service with a home as a matter of course, considering it as important as other utilities.

1.12 It is envisaged that in the near future developers will be looking to use data services within their new dwellings as selling points. These may include broadband ready homes, central security services, intelligent heat and power management. This would also act as a selling point to any developers of business and industry developments.

1.13 Wireless technologies offer flexibility for the delivery of data services and arguably a simpler implementation. However, it is understood that wire based services will still be required to deliver high data demanding services. Indeed, even wireless based services still require some form of cabling for connection to the larger service provision.



Objectives

1.14 The practical guidance in this document aims to:

- Give developers the opportunity to consider the installation of infrastructures within new developments and dwellings to support the later provision of data services by third parties.
- Reduce the risk of non-standard infrastructures (for example using ad hoc ducting types and topologies) leading to future incompatibility issues within different developments.

1.15 The guidance gives developers the opportunity to add benefits to new developments and add to the marketability of their dwellings or business premises. There is also the possibility that developing such infrastructure will allow for existing houses and businesses to 'tap into' this new infrastructure in terms of retrofitting this ducting infrastructure.

Infrastructure guidance

External infrastructure

Understanding the needs

1.16 The external infrastructure is required to facilitate the installation of cabling and possibly network equipment to support the provision of data services to dwellings. The cabling and network equipment is likely to be installed by a data service provider once a development is underway, for example when there is a revenue stream from residents. However, it may not be installed until after a development has been completed.



1.17 Ideally one or more data service providers should have been identified at the outset of a development as they may assist in the detailed design of the external infrastructure. However, it is important that the external infrastructure is not restricted by design to a given data service provider or a particular network technology. It also needs to be recognised that the external infrastructure should be available to other data service providers.

1.18 Further detailed guidance that should be considered in the design and implementation of the external infrastructure is contained within the document *Data Ducting Infrastructure for New Homes, 2008*.

The document contains information on topology and layout requirements, trenching, duct types, associated chambers, street cabinets, support for wireless technology, duct signage and layout recording, boundaries and termination and capping.

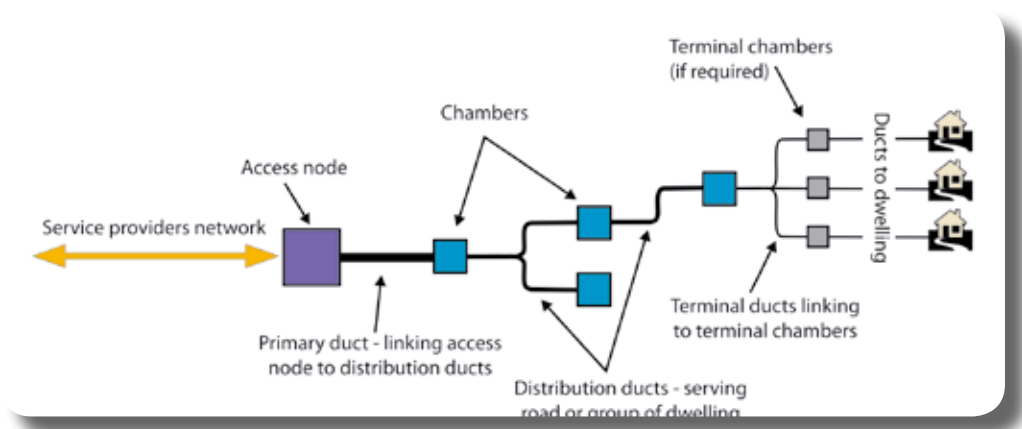

What is required

1.19 The following elements, as shown in Figure 1, need to be considered in the design and implementation of the external infrastructure:

- Access node – to provide an interface between the external infrastructure and the data service provider’s network. Depending on the network technology and the data service provider’s requirement; the access node may be implemented in a street cabinet or a chamber. The access node may be required to accommodate active (powered) network equipment.
- Street cabinets (not shown in the figure) – may be required for cable joints, cable distribution points and possibly to house active (powered) network equipment. Cabinets should be of sufficient size for additional ducting, with at least one additional duct for future requirements.
- Chambers – for cable installation, cable routing, cable jointing and some passive distribution points. Chambers may also be required to accommodate active (powered) network equipment that is designed specifically for such an environment although most data service providers are likely to favour street cabinets.
- Terminal chambers – chambers that may be required to connect the wider external infrastructure with dwellings or groups of dwellings. Terminal chambers should be located outside the dwelling plot as illustrated in Figure 1.

- Ducts – pipes to facilitate the installation and later replacement of cables. This may also include micro or inner ducts.

Internal Infrastructure

Understanding the needs

1.20 Although this document is intended to provide guidance with respect to data services it is important that the support of such services within the dwelling be considered in the wider context of other cable distribution requirements. Some of the equipment that may require cabling within a typical dwelling may be considered as:

- Communications, entertainment and other equipment that require broadband or at least basic internet connectivity. The connection of such equipment is the prime focus of this guidance.
- Other equipment that may require an external network connection other than the internet.
- Systems and equipment that require cabling within the dwelling but may or may not have any need for external connectivity.

1.21 Equipment within the dwelling may employ a wide range of cabling of both a standard and proprietary type. Some may also connect using a wireless technology. Both cabling and wireless solutions are evolving and any internal infrastructure will need to offer sufficient capacity and flexibility to meet future requirements.

1.22 It should be noted that some of the data connectivity requirements within a dwelling may be met using a wireless solution rather than a cabled solution. The use of wireless technologies is outside the scope of this document. However, ducting is still required to support cabling to wireless hardware.

1.23 It is clearly impossible to pre-cable a dwelling to support all possible applications. Indeed, the current provision of telephone and television sockets in homes is often inadequate and lacking in flexibility. The result is that many dwellings have extensive cabling that is often surface mounted or trailed across floors.



What is required

1.24 Occupants of dwellings are likely to require:

- data sockets at useful locations throughout the dwelling;
- a readily accessible location where network equipment can be installed with a simple user-friendly method of connecting the network equipment to live data sockets; and
- mains electricity sockets located near the data sockets.

1.25 The possibility of installing data sockets at useful locations will depend on the nature of the dwellings and the type of occupancy. However, diverse user needs can only be met by a flexible infrastructure that will allow sockets to be readily installed as and where required. Such a flexible infrastructure would also offer the potential for supporting other cabling distribution requirements.

1.26 It is not envisaged that developers install data sockets, data cabling or the associated network equipment although some may choose to do so. Rather developers should install internal ducting that enable the later installation of data cabling, faceplates and sockets, and network equipment with minimal disturbance to either previously installed cables or the fabric of the building. The aim should be to facilitate cable installation by an electrician or a qualified competent person.

1.27 The internal infrastructure should be limited to the supporting faceplates and sockets at normal height but consideration should be given for sockets and faceplates that maybe located at a higher location within the dwelling to facilitate a wireless solution or wall mounted media systems such as a flat screen television.

1.28 The internal infrastructure should also be designed to support the installation of devices at ceiling level such as sensors for home security and telecare and ceiling mounted loudspeakers.



Future proofing

1.30 It is important to note that as technological advances are made that materials and construction methods may well change in the future, therefore developers should ensure that when developing a site with digital ducting that they do so using the most up-to-date construction methods and technologies where possible. If such changes in the future are significant, the council will provide updated guidance where it considers this appropriate.

Conclusion

1.31 To conclude, this SPG gives the background to the issue of digital ducting infrastructure in new developments and also points prospective developers to other helpful and more technical documentation to enable them to make informed decisions about ducting for digital infrastructure. to serve their developments as possible. However, the council would recommend that developers seek their own independent professional advice before deciding how to proceed.

Disclaimer Please note that this supplementary planning guidance has been produced to assist readers by providing guidance on practical and technical issues concerned with laying ducting for data service delivery. The document does not purport to provide guidance on the law, and if readers have any queries about any legal issues relating to the document they are advised to seek their own legal advice. In addition, where the document refers to an interpretation of the law, readers should not rely on that interpretation without seeking advice from an appropriate source.

NB Hyperlinks are included throughout this document in the graphics and text. Use the mouse to scroll over pages to find these links.

Further information

For further information or specific advice please contact:

Steven McLucas,
Planning Officer and e-planning Project Manager,
Development Planning,
West Lothian Council, County Buildings, Linlithgow. EH49 7EZ

Telephone: 01506 775268

Email: steve.mclucas@westlothian.gov.uk

Andy Gilpin, e-Business Adviser,
West Lothian Council Business Enterprise,
Almondvale Boulevard, Livingston, West Lothian EH54 6QP

Telephone: 01506 777998

Email: andy.gilpin@westlothian.gov.uk

Alice Sinnet, Business Development Manager,
West Lothian Council Business Enterprise,
Almondvale Boulevard, Livingston, West Lothian EH54 6QP

Telephone: 01506 777924

Email: alice.sinnet@westlothian.gov.uk

April 2010

westlothian.gov.uk



West Lothian
Council